

Status of the LatFor DataGrid (LDG)

D. Pleiter (DESY Zeuthen)

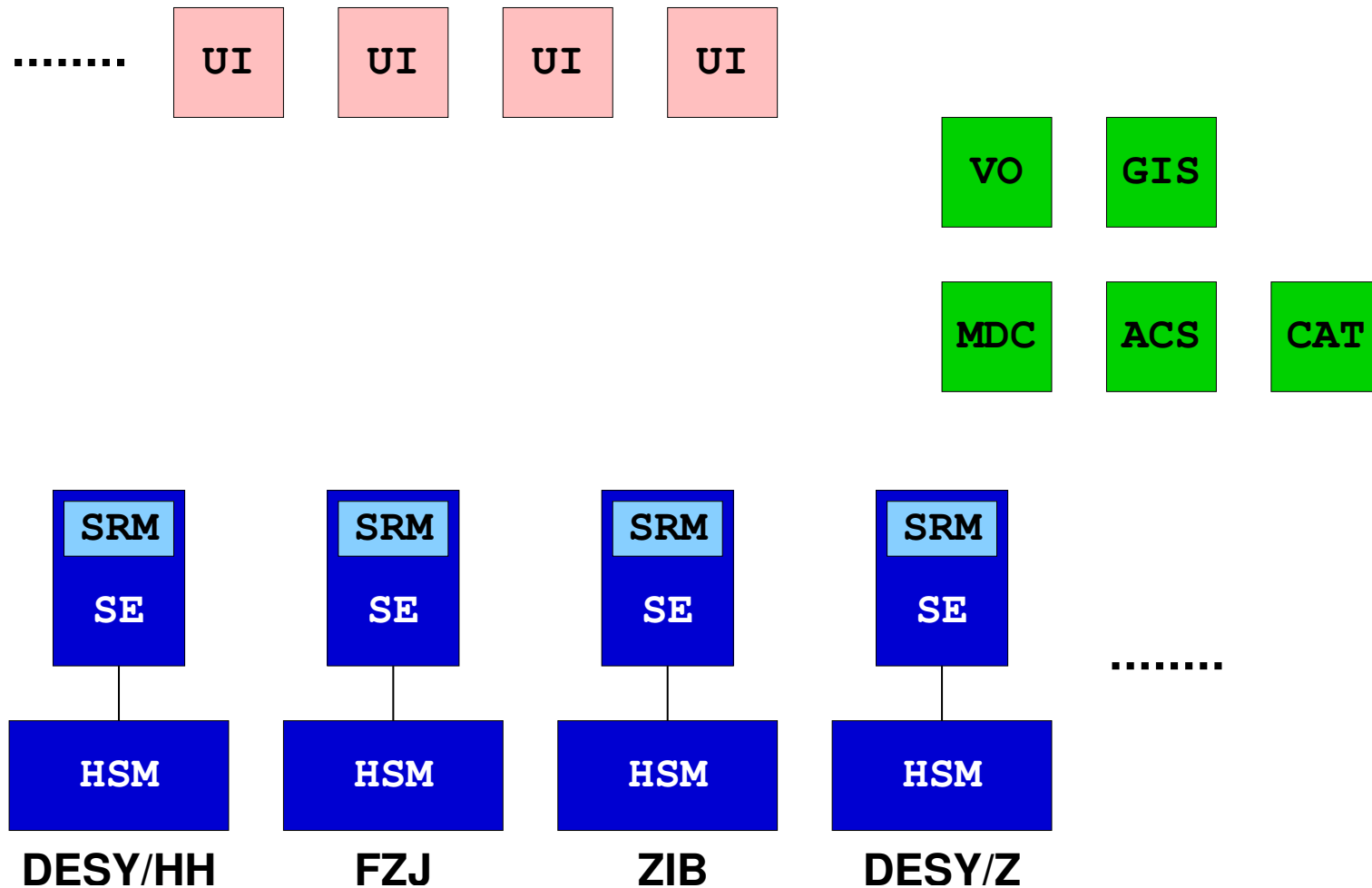

LatFor DataGrid Components



Status

- ❑ Metadata Catalogue (MDC):
 - Almost all features implemented
 - Web-service front-end
 - Web-interface: <http://www-zeuthen.desy.de/latfor/ldg>
- ❑ Middleware services:
 - dCache-based Storage Elements (SRM1 interface)
 - EDG file catalogue (soon: LCF)
 - Virtual organization (VO) 'ildg'
- ❑ User tools:
 - Prototype versions for get, put and ls operations ready

Planned Grid Content

- SESAM/T χ L/GRAL:
 - $N_f = 2$ Wilson fermions, plaquette glue
 - $m_{PS} = 419, \dots, 900$ MeV
 - $a = 0.08, \dots, 0.13$ fm, $V = 0.9, \dots, 2.1$ fm
- QCDSF
 - $N_f = 2$ NP-Clover fermions, plaquette glue
 - $m_{PS} = 590, \dots, 1170$ MeV
 - $a = 0.07, \dots, 0.11$ fm, $V = 1.4, \dots, 2.0$ fm
- Twisted-mass Collaboration
 - $N_f = 2$ twisted-mass fermions, tree-level Symanzik glue
 - $m_{PS} = 250, \dots, 500$ MeV
 - $a \approx 0.08, \dots, 0.13$ fm, $V = 2.1, \dots, 2.6$ fm
- Other: INFN/CNRS, Alpha

Outlook: Ellegrid

- ❑ Our goals from a lattice point of view:
 - Provide support for lattice groups
 - Get resources for ILDG-Middleware
- ❑ From a Grid point of view:
 - Lattice is a new application for Grid technologies
 - Opportunities:
 - sharing data at a global level
 - seamless access to heterogeneous computing resources
 - Interoperability is a general problem which needs to be solved
- ❑ Work program:
 - Define lattice requirements
 - Test/design/implement solutions for interoperability issues
 - Setup EGEE-based infrastructure
- ❑ Participants: CNRS (F), DESY (D), EPCC (UK), INFN (I)
Associated participants: Japan, Australia