CLAS12 forward detector: Pre-shower

Concept, R&D, PED ...

S. Stepanyan (JLAB)

Contributing institutions:

YerPhI, JMU, OU, NSU, Orsay-IPN

CLAS12 Detector Workshop, February 2-3, 2007 , JLAB

CLAS FEC

The width of transverse readout segmentation of the CLAS FEC is ~10cm

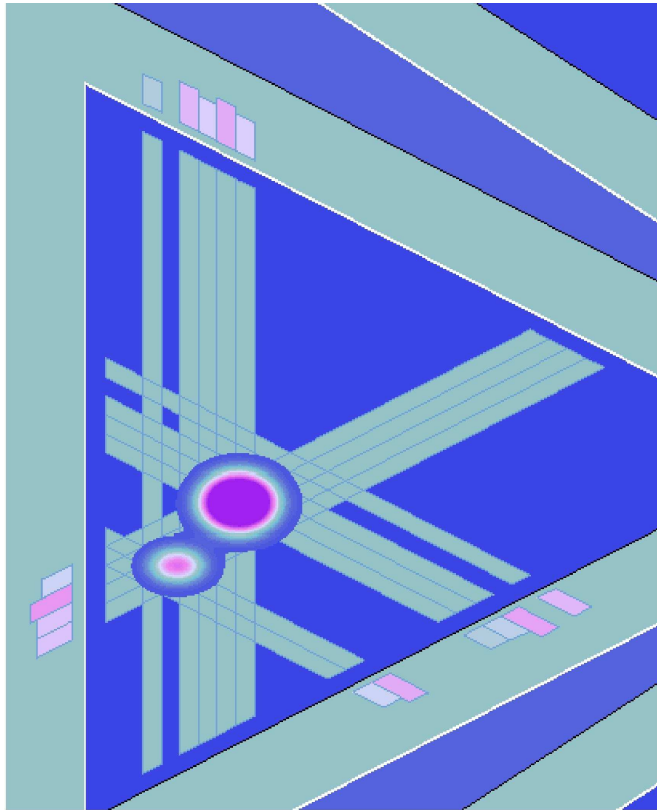

With increase of pion momentum, the opening angle (distance) between decay photons in $\pi^0 \rightarrow \gamma\gamma$ becomes small to reconstruct them as separate clusters

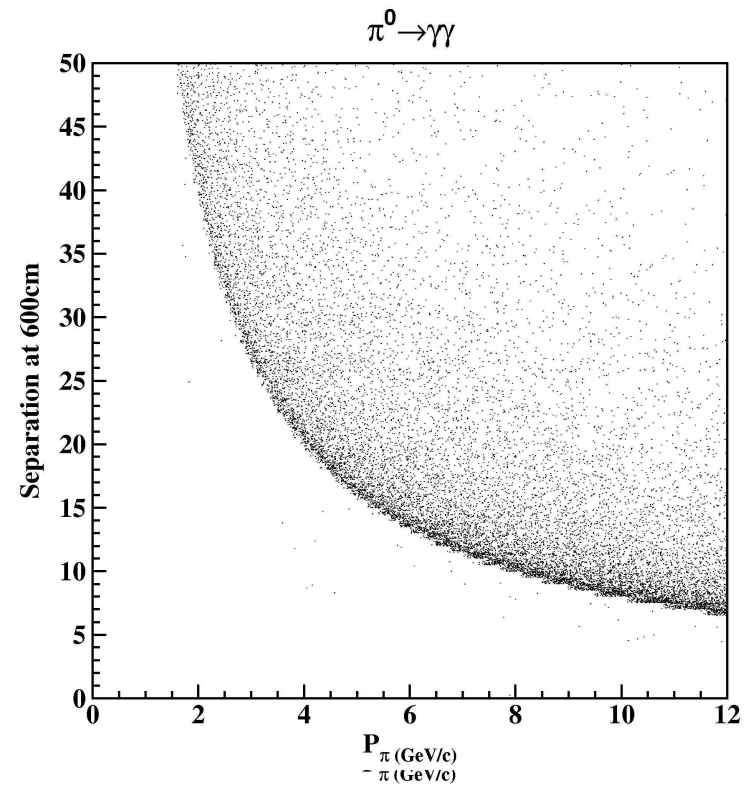

Initial proposal for the pre-shower calorimeter

Basic structure - similar to FEC:

- lead-scintillator sandwich

- three stereo readout

- 9 layers of scintillators and lead

- Scintillator layer segmentation – 3cm

Covers only forward half of the FEC

Light transport to the photo-detector via green wave-shifting fibers embedded in groves on the surface of the scintillator strips

Light readout via 1" PMT with green sensitive photocathode

CLAS12 pre-shower project

WBS 1.4.2.2.2.3 - ~\$1M

Discription	FY06	FY07	FY08	FY09	FY10	FY11
R&D	■	■				
PED		■	■			
Construction				■	■	
Checkout and Installation					■	■

■ R&D:

- full GEANT simulation and reconstruction
- selection of the scintillator material, wave shifting fibers, and the PMT
- build and test a prototype

■ PED:

- design of a box with end plates and mounting fixtures
- design of the fiber routing and PMT holders
- Design of the prototype

R&D: GEANT implementation and simulation of the pre-shower

N. Dashyan (YerPhI), K. Whitlow (SULI)

CLAS-NOTE 2007-001 & CLAS-NOTE 2007-002

Goals:

- ❑ establish optimal design parameters of the pre-shower
- ❑ determine characteristics of electromagnetic shower and $\pi^0 \rightarrow \gamma\gamma$ reconstruction in the CLAS12 forward electromagnetic calorimeter

Tools:

- ❑ simulation in GSIM, the pre-shower positioned in front of EC
- ❑ reconstruction in RECSIS, using modified EC package

Pre-shower in GSIM

One PCAL modules in each sector

The pre-shower is a lead-scintillator sandwich with 10 mm thick scintillator layer followed by 2.2 mm thick lead sheet

Every triangular scintillator layer was sliced parallel to the one of the edges of the triangle into up to 108 equal width strips. The slicing alternates with each scintillator layer, forming three orientations U, V and W, repeats in every fourth layer (3-stereo readout planes)

Modules with 9, 12, and 15 scintillator layers and 15 layers of lead were tested

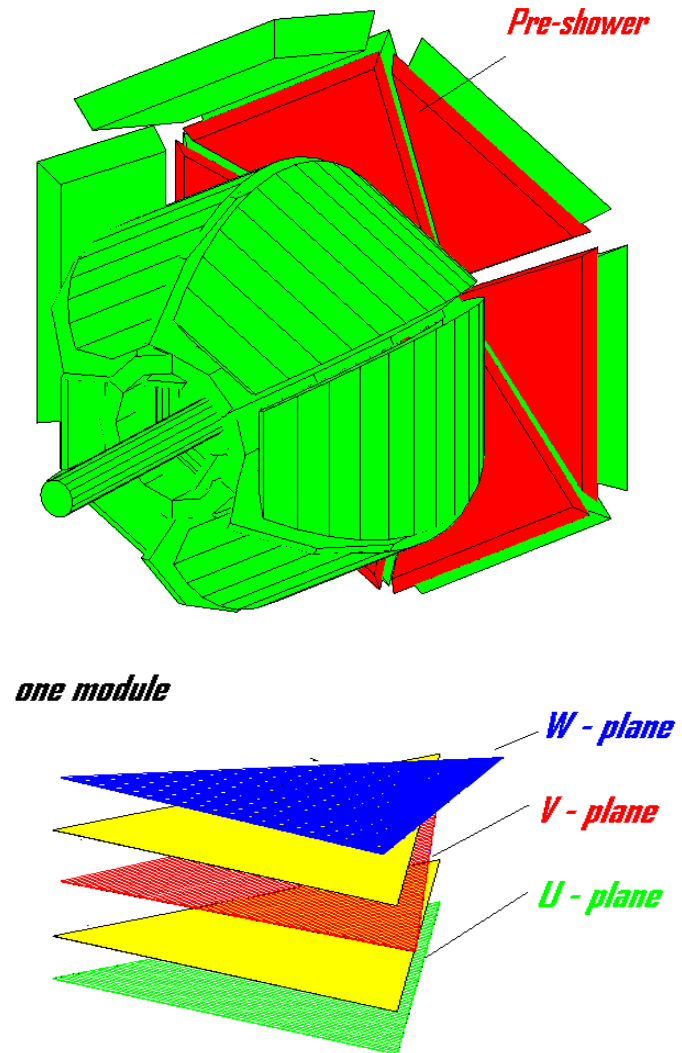

Main results

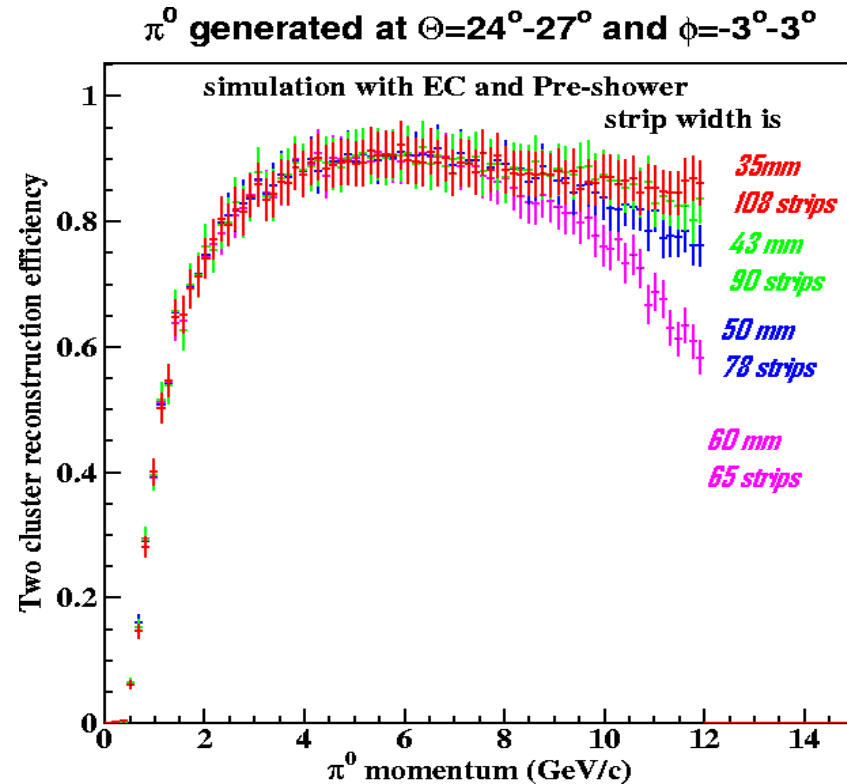
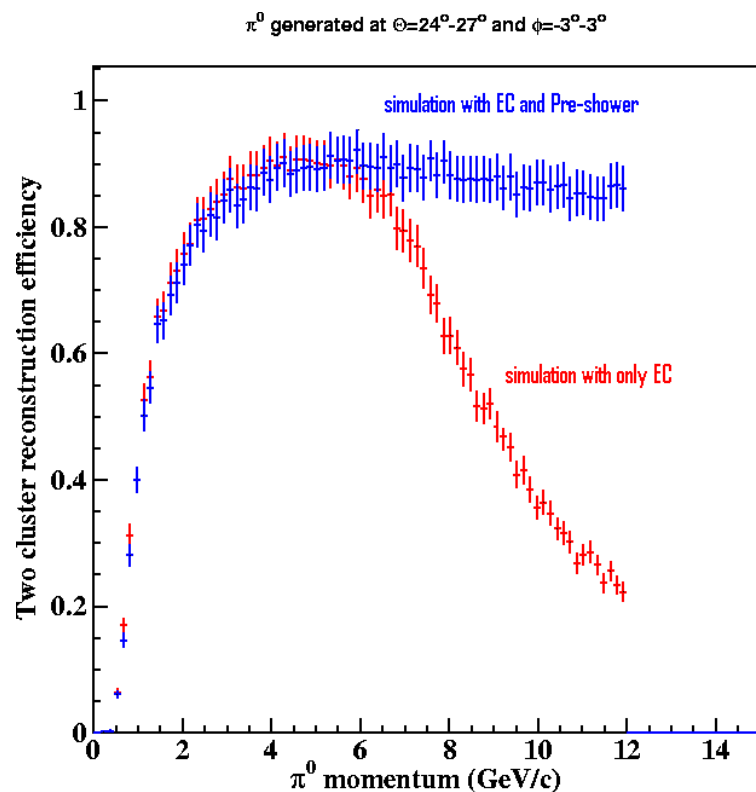

Optimal configuration based on a single photon detection efficiency, shower energy resolution, and the reconstruction efficiency of two clusters from π^0 decay is: **15 layers** of lead and scintillators with **4.5 cm wide** strips in forward region

Double strip readout at large angles - limit 196PMTs/sector

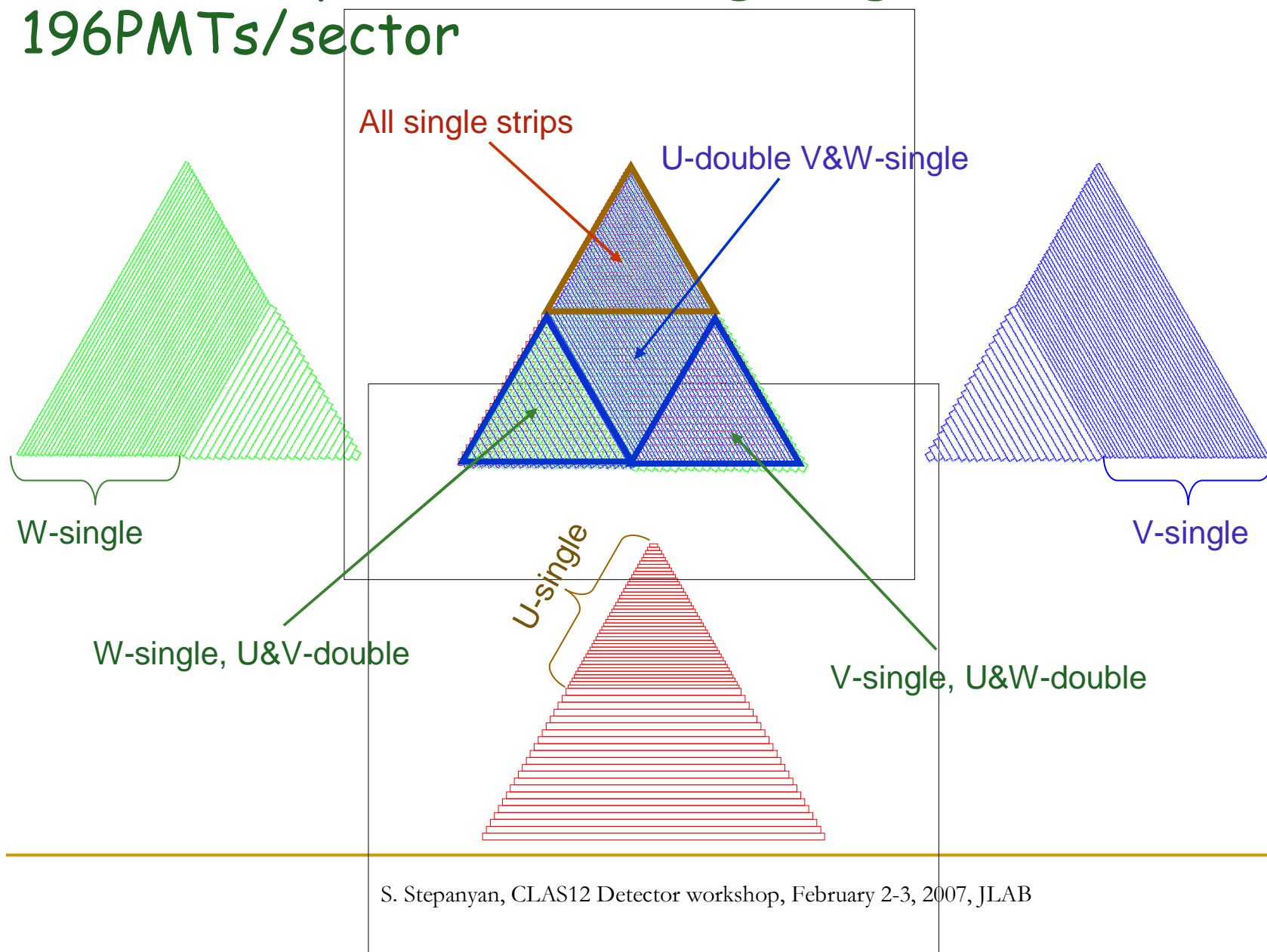

Summary of simulations

- Initial design parameters of the pre-shower are set using a full GEANT simulation (see CLAS-NOTES):
 - 15 layers of the lead and scintillator, 2.2mm lead, 10mm scintillator
 - 4.5 cm segmentation of the scintillator layers in forward region

Must be done:

- Implementation of a final arrangement of the readout segmentation after initial design is finished
- π^0 reconstruction efficiency studies with realistic event generators
- Implementation of the photoelectron statistics and the attenuation of the light in the fibers for determination of realistic energy resolution
- Integration of the PCAL into CLAS12 GEANT4 framework

R&D: Test of the readout components and the prototype

G. Asryan, H. Voskanyan, Hall B engineering

Tests include:

- ❑ measurements of a relative light yield for several different scintillator-fiber-PMT combinations
- ❑ study multiple fiber readout
- ❑ study light attenuation and the time characteristics for the scintillator-fiber-PMT combinations with the highest light yield

The final combination of scintillator-fiber-PMT will be selected based on performance and the price

Build a prototype to check the design of individual elements, to test assembly procedures, and the pre-shower performance

Pre-shower components for test

PMT	Type	Quantity	Divider	Quantity	Socket	Quantity	Total price
HAMAMATSU	R7899	4	R7899	2		4	1784
Electron Tubes	9124B	2	C637A	1	B14B	1	906
PHOTONIS	XP1912	1	DV108	1			697
	XP2802	1	DV1A8	1			
Fibers	Type	Diameter	Length	Quantity	Total		
Kuraray	Y-11	2mm	2,5m	14	35m		1575
	Y-11	1.5mm	2.5m	14	35m		
	Y-11	1mm	2.5m	14	35m		
Bicron	BC-91A	1mm	2.5m	80	200m		800
	BC-92	1mm	2.5m	80	200m		
Scintillator							
ELJEN Technology	4F.	3x1cm2	2 m	2	4m		1974
	0F.	3x1cm2	2m	2	4m		
Kharkov	1F.	4x1cm2	1m	1	1m		0
	2F	2.63x1.06cm2	2m	20	40m		600
	3F	2.63x1.06cm2	2m	20	40m		800
Fermi Lab	1F.	4x1cm2	1m	5	5m		0
ITEP	1F.	4x1cm2	1m	1	1m		0
						Total:	9136

Test setup (in the EEL)

4 m long dark box with moving cart and support fixtures (Hall B engineering)

Simple DAQ (CODA) – FASTBUS with LeCroy ADC

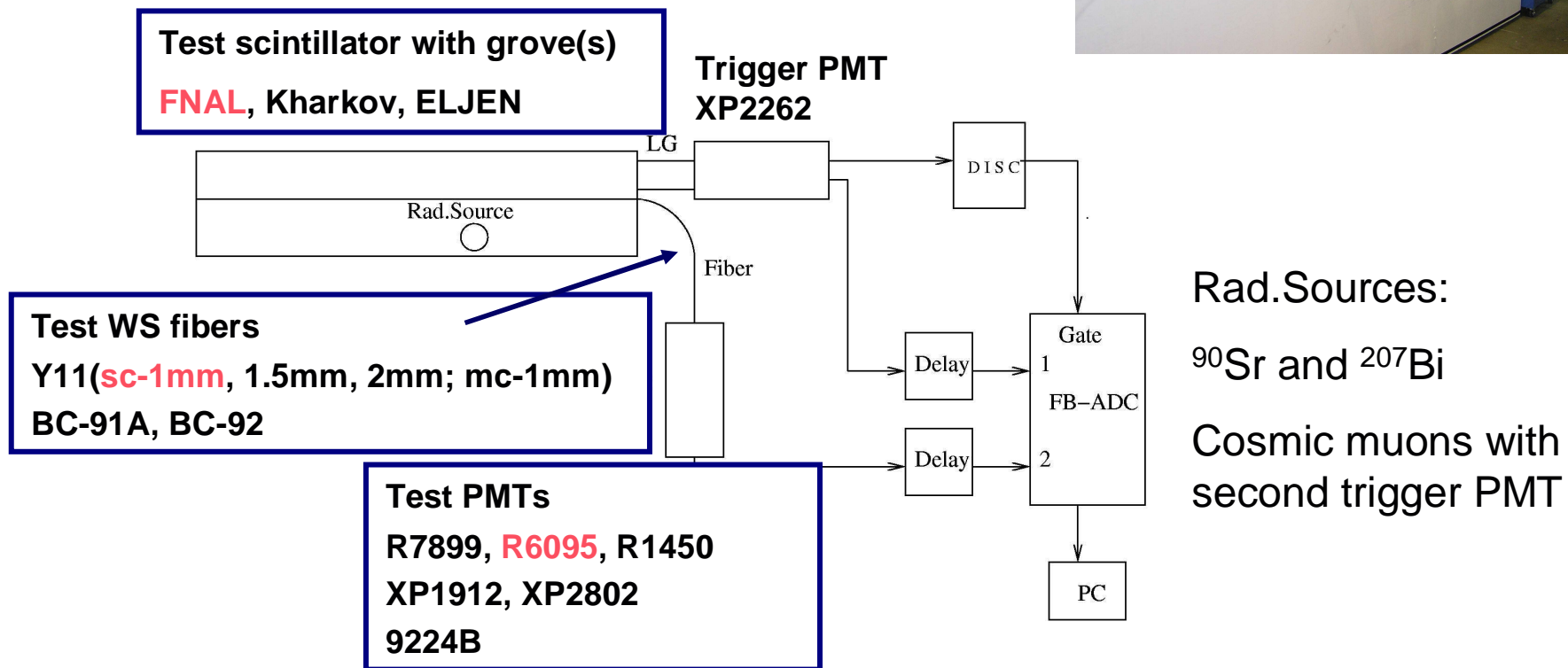

Rad.Sources:

^{90}Sr and ^{207}Bi

Cosmic muons with
second trigger PMT

Measurements technique

- For each PMT, a single photoelectron peak position and the width, at given HV, was determined using two Gaussian fit to the ADC distributions of attenuated light
- For each combination, the average number of photo-electrons was extracted as a function trigger PMT ADC value, the fit function:

$$ADC_T = c_1 \sum_i P_i(n_{pe}) \times C_i(n_{ch}) + c_2 e^{-\frac{(x-x_p^0)^2}{2\sigma_p^2}}$$
$$P_i(n_{pe}) = \frac{(n_{pe})^i e^{-n_{pe}}}{i!}$$
$$C_i(n_{ch}) = \frac{1}{\sigma_1 \sqrt{i}} e^{-\left(\frac{n_{ch}-c_3 a_1}{\sigma_1 \sqrt{2i}}\right)^2}$$

Fit parameters: c_1 , c_2 , c_3 , and n_{pe}

Fits to ADC distributions

Hamamatsu R7899EG,
Green sensitive
photocathode

FNAL scintillator with one
grove, Kurary Y-11 single
clad fiber

Hamamatsu R6095,
15% QE at 500nm

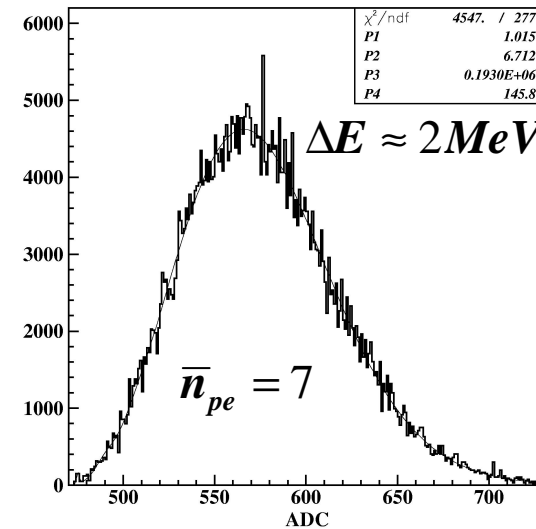
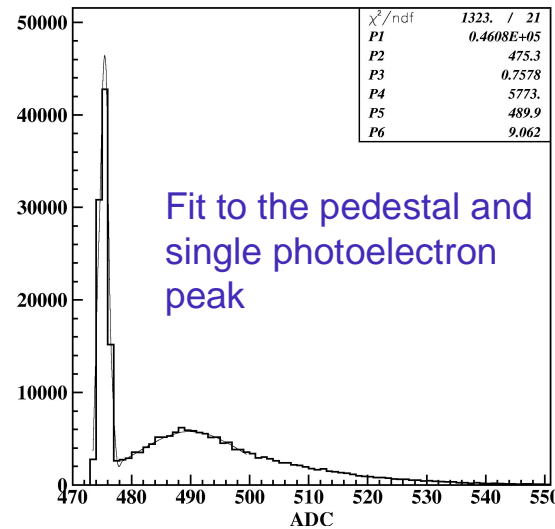
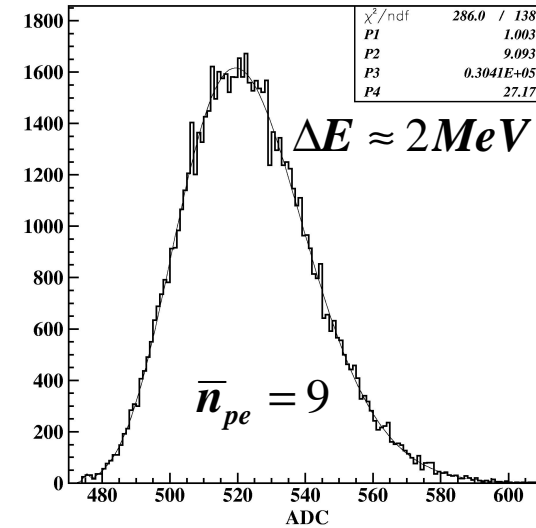
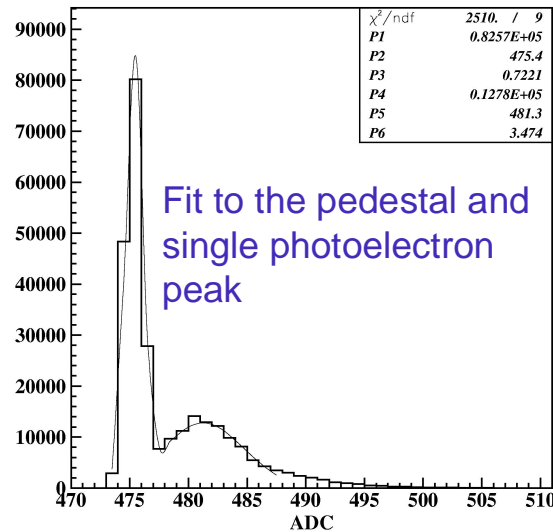

Fit to the ADC distributions from ^{90}Sr

Fit to slices of trigger PMT ADC distribution

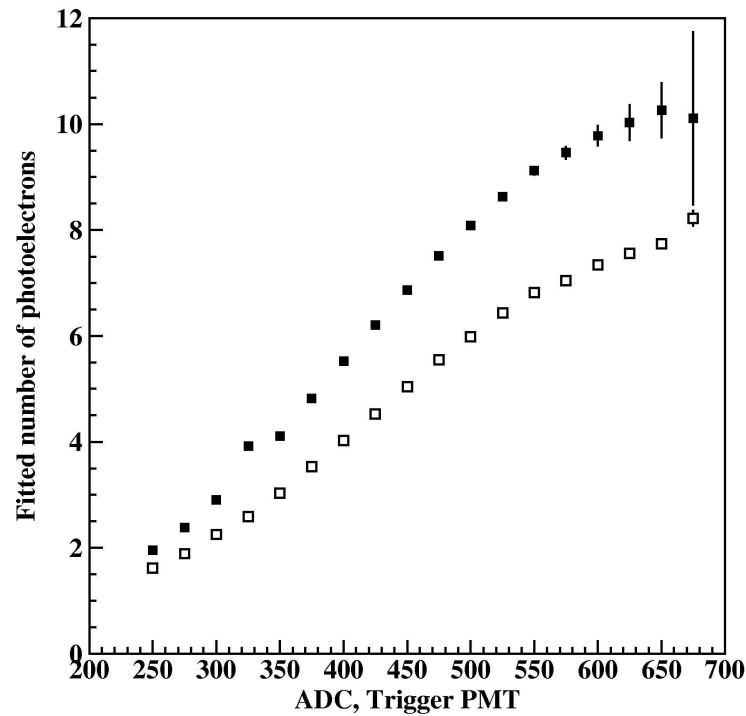
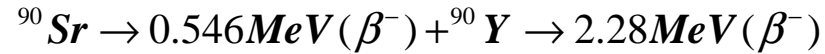

Scintillator strips with 3-grooves, Kharkov. ADC distributions of XP2802 for one, two, and three fiber readout

$$n_{pe}(3 \text{ fibers}) \approx 3 \times n_{pe}(1 \text{ fibers})$$

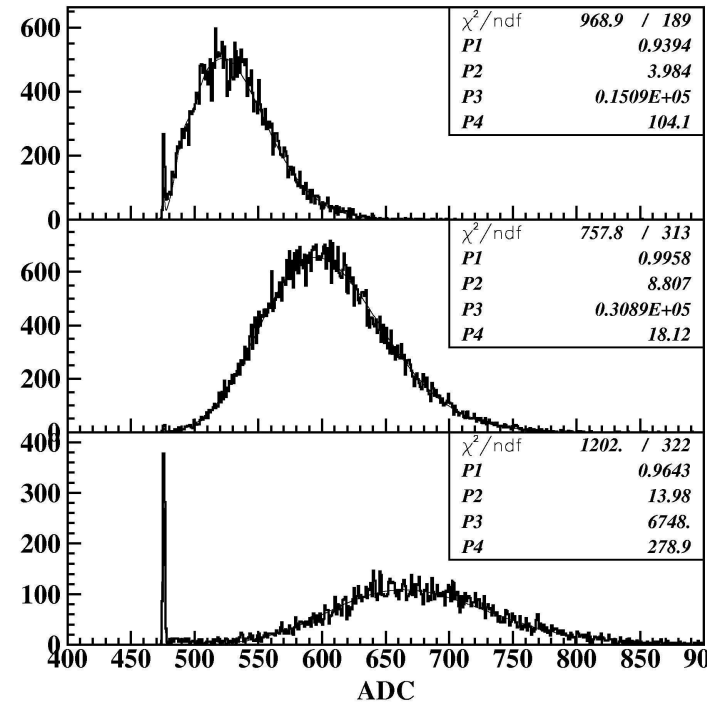

Absolute light yield with cosmic muons

FNAL scintillator, 1 cm thick, with 1mm WS fiber,
Kurary Y-11 s.c., PMT Hamamatsu R6095

7-8 photoelectrons

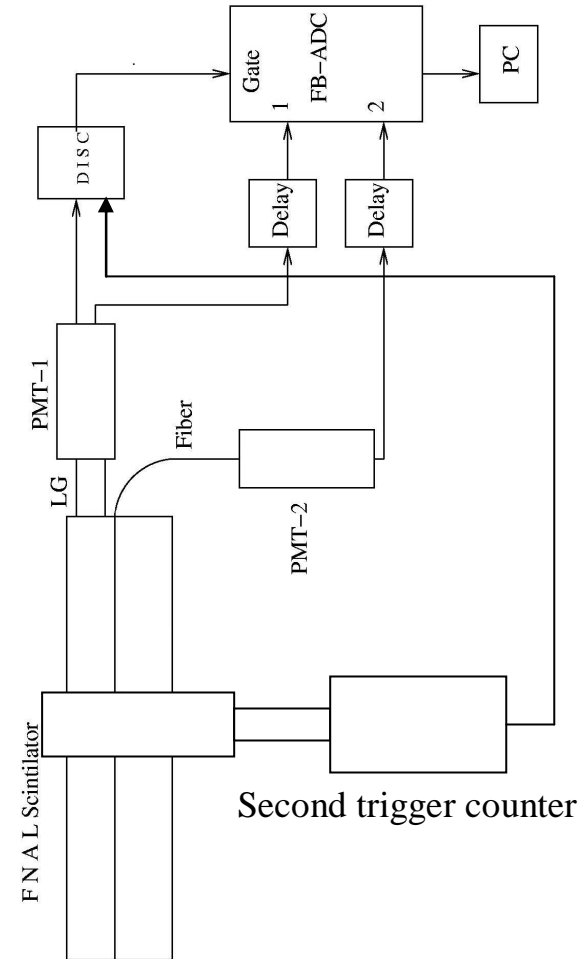
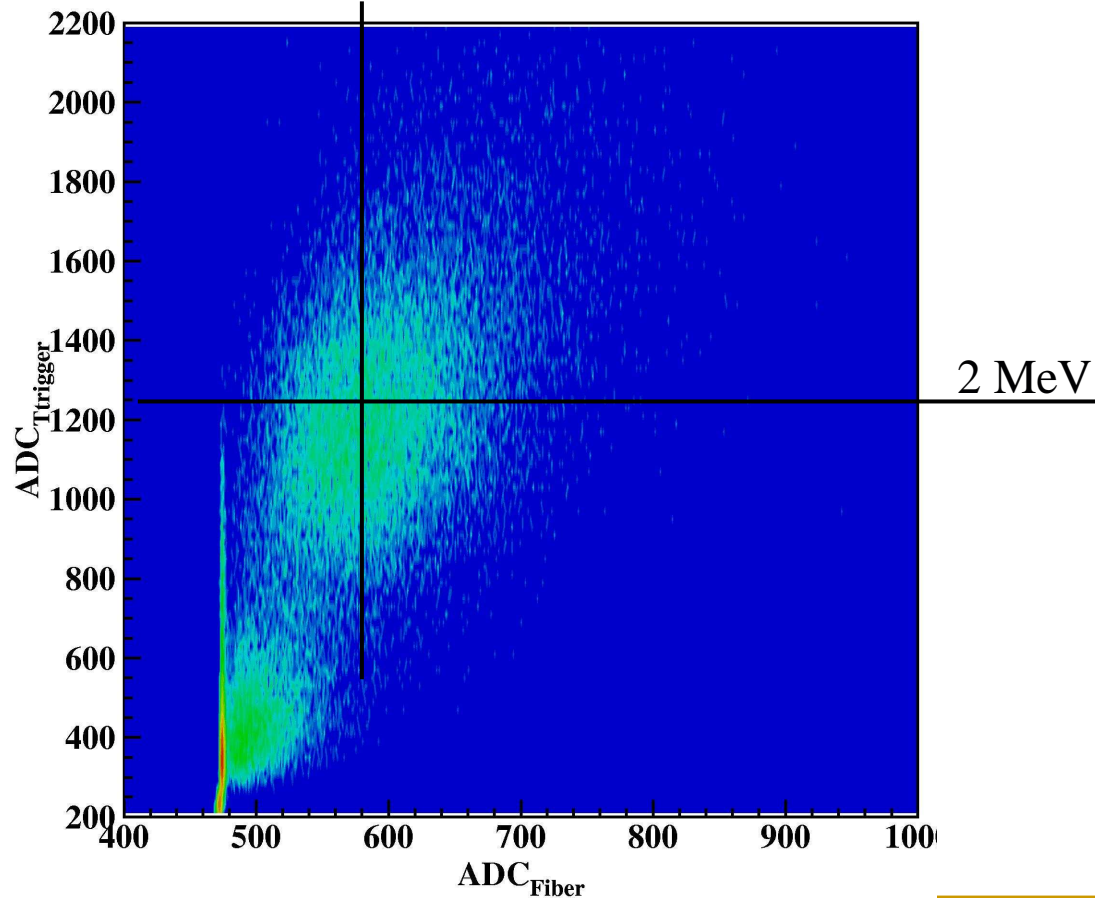

Summary of test measurements

- By performance the best PMT HAMAMATSU R7899EG, \$280/each. Photoelectron yield of the HAMAMATSU R6095, selected with 15% QE at 500nA, for the same scintillator and fiber, is lower only by 25%. Price for R6095 is \$180(\$160). All other PMTs, yet with green sensitive photocathode, did not perform that well and are expensive, >\$250
- Multi-clad fiber produces 20% more light than a single-clad, but 30% more expensive
- FNAL extruded scintillator with Y-11 fiber has the best light yield, mostly due to good reflective cover. It is also reasonable in price, \$20-\$25/meter. Scintillators from Kharkov are close, but will need R&D to match the performance of FNAL scintillators
- The best combination by light yield and price is: **FNAL scintillator – Kurary Y11 single clad – HAMAMATSU R6095. Light yield ~11p.e./MeV for 3 fibers (light yield for FEC readout ~7p.e./MeV)**

Next in test measurements

- Production of a new FNAL scintillators with 1×4.5 cm² cross section and with three grooves on the surface will start next week
- Long scintillator strips will be produced for attenuation length measurements
- After extruder is tuned, scintillator strips for a prototype can be ordered
- Proposed prototype - 15 layers with 32-U, 32-V, and 32-W strips
- Prototype will be used to workout design details, assembly procedures, and the pre-shower performance
- Before the main prototype, a small scale prototype with two orthogonal views can be build

PED FY07

The goal of the PED in FY07 is the initial design of the pre-shower that can be used to build a prototype

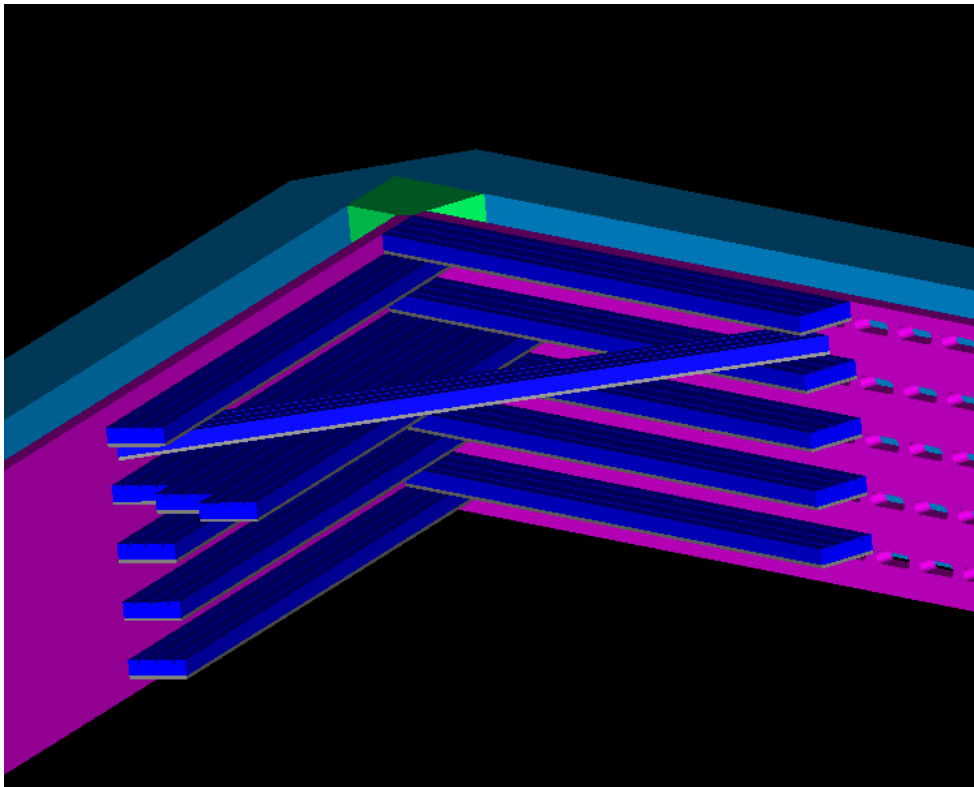

Pre-shower model is in IDEAS with few details: front and back plates, side walls, scintillator holders

Concept of support from FEC and central hub is in development

There is a concept of PMT mount

Arrangement of the scintillator and lead layers are in progress

Summary

- Pre-shower R&D and PED are in progress
- Main design parameters were established using the full GEANT simulations
- Advances in the reconstruction allowed to use wider readout segmentation
- New design covers ~4 times bigger area with the same number of readout channels and has more layers
- Final combination of scintillator-fiber-PMT is selected based on light yield measurements
- FNAL is working on the production of scintillator strips with exact geometry
- More measurements will be done using these new scintillators as a part of R&D
- For prototype components must be ordered soon